

ALPS SERIES FILTERS



Designed and Built for Exceptional Performance

OMI's advanced Alps Series compressed air filters reduce contamination in your air stream to help protect your critical processes and valuable equipment.

Our filters are rigorously tested and engineered with superior components to provide years of reliable performance and consistently high-quality air.



Better Quality

Without effective filtration, products and processes that depend on compressed air are subject to increased scrap, poor quality and additional maintenance.

OMI Alps Series filters address these issues, helping to assure your compressed air system delivers clean, high-quality air throughout your facility.



Better Efficiency

Maintaining a low pressure drop on all compressed air components is critical for an energy-efficient system. OMI Alps Series filters have been engineered to deliver low pressure drop throughout the life of the filter element and to provide a unique dual indicator that illustrates the true cost of pressure drop on the system.

Better Choices

Every compressed air system has unique filtration requirements. Alps Series filters are available in four different filtration grades, providing complete filtration solutions for all critical compressed air processes.



Quality by choice



RINA
ISO 9001 - ISO 14001
BS OHSAS 18001
Certified Integrated Systems

Superior Filtration Technology

- A Patented dual indicator (optional)** shows differential pressure drop and economical operating efficiency
- B Patented smooth bore flow insert** directs air into the filter element, minimizing turbulence and pressure losses
- C All-aluminum, precision die cast body** suitable for 100°C and 20 bar g MAWP applications
- D Proprietary coating** applied to the inside and outside surfaces provides corrosion protection in harsh industrial environments
- E Filter element with stainless steel mesh** withstands high differential pressure while minimizing flow restriction through the element
- F Ergonomic bowl design with no-touch filter element** simplifies element replacement
- G Time strip label** indicates when it's time to change the element (CF Grade only)
- H Industrial-grade brass float drain (optional)** discharges accumulated condensate and oil more reliably than lesser quality plastic drains (no-loss and manual drains also available)
- I Deep-pleated filter media** reduces air flow velocity to maximize filtration efficiency and minimize pressure losses
- J High-efficiency drainage layer** improves liquid drainage properties and enhances chemical compatibility
- K Simple visual alignment** of the filter head and bowl ensures accurate assembly of components and helps to improve safety



Complete Filtration Solution

Alps Series filters are engineered to be a complete filtration solution, incorporating features that address air quality, energy efficiency and ease of maintenance.

The Standard for High-Quality Air

Alps Series filters provide clean, high-quality air as defined by ISO 8573.1:2010, and are certified by a third party under ISO 12500-1. With multiple filter element grades available, there is a filtration solution that will meet your unique requirements.

Energy Efficient Through and Through

Pressure drop accounts for over three-quarters of the ownership cost of a compressed air filter. Even when a filter element is clean and dry, it can rob a compressed air system of pressure, causing the air compressor to work harder and increase energy costs. The flow path through the Alps Series filter housing reduces turbulence and enhances efficiency, while the deep-pleated element design further minimizes pressure drop.

Designed with Maintenance in Mind

Features such as no-touch element replacement and visual bowl-to-head alignment indicators make maintaining the Alps Series filter hassle-free. The “zero-clearance” design requires minimal space around the filter, allowing Alps Series filters to be installed where other filters won’t fit. Long element life provides efficient operation for up to one year between element changeouts, helping to reduce overall ownership costs*.

* Frequency of element changeout will depend on the unique conditions of each customer’s air system.

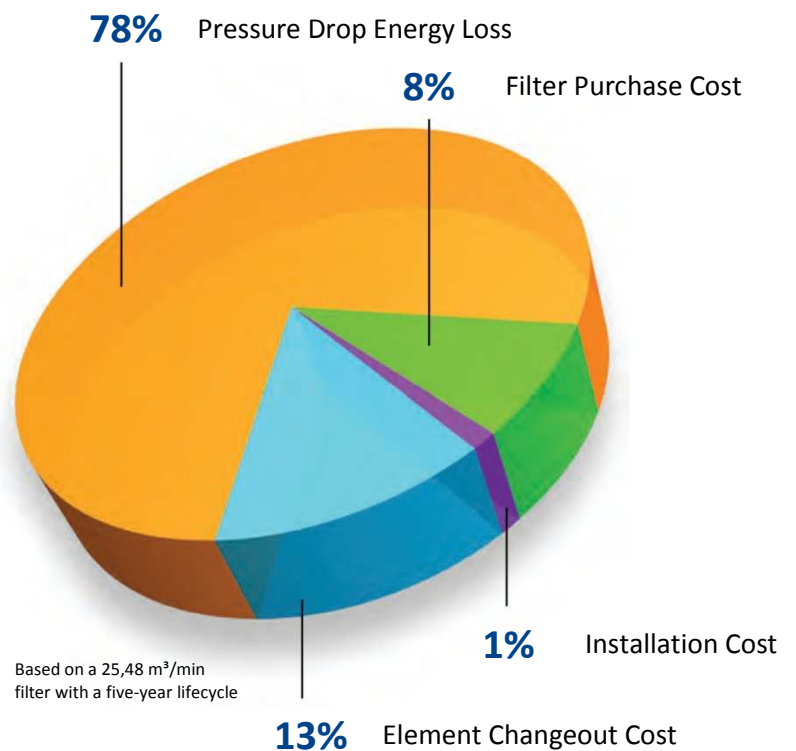

Quality Assured by OMI

OMI has more than 20 years of air filtration experience. Our manufacturing facility ensures quality, reliability and outstanding performance. Our filters undergo advanced testing and are uniquely designed and manufactured to work with the full range of OMI products.



Alps Series Filter Specifications

Model	PF Code	HF Code	CF Code	QF Code	Flowrate			Max pressure	Connections	Dimensions			Weight
					l/min	m³/h	CFM			A	B	C	
AF30	04A.0030AP	04A.0030AH	04A.0030AC	04A.0030AQ	500	30	18	20	3/8"	177	76	20	0,6
AF40	04A.0040AP	04A.0040AH	04A.0040AC	04A.0040AQ	667	40	24	20	1/2"	177	76	20	0,6
AF75	04A.0075AP	04A.0075AH	04A.0075AC	04A.0075AQ	1250	75	44	20	3/4"	232	98	26	1,1
AF110	04A.0110AP	04A.0110AH	04A.0110AC	04A.0110AQ	1833	110	65	20	3/4"	232	98	26	1,1
AF190	04A.0190AP	04A.0190AH	04A.0190AC	04A.0190AQ	3167	190	112	20	1"	272	129	36	2,1
AF260	04A.0260AP	04A.0260AH	04A.0260AC	04A.0260AQ	4333	260	153	20	1"	272	129	36	2,1
AF400	04A.0400AP	04A.0400AH	04A.0400AC	04A.0400AQ	6667	400	235	20	1 1/2"	362	129	36	2,4
AF500	04A.0500AP	04A.0500AH	04A.0500AC	04A.0500AQ	8333	500	294	20	1 1/2"	362	129	36	2,4
AF800	04A.0800AP	04A.0800AH	04A.0800AC	04A.0800AQ	13333	800	471	20	2"	470	170	44	5,2
AF1000	04A.1000AP	04A.1000AH	04A.1000AC	04A.1000AQ	16667	1000	589	20	2"	470	170	44	5,3
AF1300	04A.1300AP	04A.1300AH	04A.1300AC	04A.1300AQ	21667	1300	765	20	2 1/2"	631	200	50	7,6
AF1560	04A.1560AP	04A.1560AH	04A.1560AC	04A.1560AQ	26000	1560	918	20	3"	652	205	61	10,7
AF1830	04A.1830AP	04A.1830AH	04A.1830AC	04A.1830AQ	30500	1830	1077	20	3"	652	205	61	10,7
AF2700	04A.2700AP	04A.2700AH	04A.2700AC	04A.2700AQ	45333	2720	1601	20	3"	882	205	61	13,7

Grade CF - Activated Carbon Filtration

Oil vapor and hydrocarbon odor removal, providing a maximum remaining oil content of <0,003 mg/m³ (<0,003 ppm) @ 21°C (Precede with Grade HF filter)

Grade PF - General Purpose Protection

Particle removal down to 0,1 micron including coalesced liquid, water and oil, providing a maximum remaining oil aerosol content of 0,1 mg/m³ (0,1 ppm) @ 21°C

Operating Limitations:

Maximum Operating Pressure	20 bar g
Maximum Recommended Operating Temperature	100°C (Grade PF, HF, QF)
Maximum Recommended Operating Temperature	60°C (Grade CF)
Minimum Recommended Operating Temperature	1°C

Grade HF - High Efficiency Oil Removal Filtration

Particle removal down to 0,01 micron including water and oil aerosols, providing a maximum remaining oil aerosol content of 0,01 mg/m³ (0,01 ppm) @ 21°C (Precede with Grade PF filter)

Grade QF - General Purpose Dust Filtration





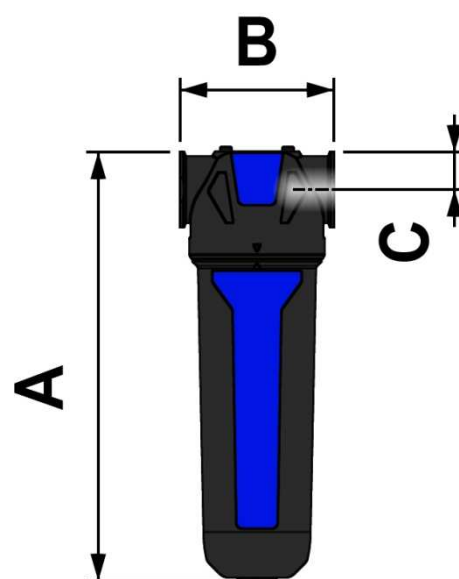

Dust particle removal down to 1 micron

Line pressure	bar g	1	2	3	5	7	9	11	13	15	16	17
Correction factor		0,38	0,53	0,65	0,85	1,00	1,13	1,25	1,36	1,46	1,51	1,56

To use correction factors, multiply the filter's capacity by the correction factor to get the new filter flow capacity at the non-standard operating pressure. For example, a 190 m³/h filter operating at 11 bar has a correction factor of 1,25. 1,25 x 190 = 237,5 m³/h capacity at 11 bar.



Available options

DIFFERENTIAL PRESSURE GAUGE Displays the exact grade of saturation of the filter element. Max. Temperature: 80°C		MANUAL DRAIN 1/2" ball valve manual drain.	
AUTOMATIC DRAIN Automatic auto drain suitable for Alps series filters. Completed with manual testing drain. Max. Pressure: 17 bar – Max. Temperature: 80°C		SC-CHROM – TIMED DRAIN Thanks to the use of a timer that controls interval and duration of operation, this drain is widely used in compressed air industry. Max. Pressure: 16 bar	
SC-12M – FLOATING DRAIN This simple type of automatic drain is used to discharge the condensate from air tanks, filters, air dryers, etc. It is supplied with manual testing drain and connection nipple with compensation tube. Max. Pressure: 16 bar		ZERO DRAIN Specifically designed to reduce to zero: - the air consumption thanks to the capacitive control; - the maintenance thanks to the Replacement kit; - the space for the installation underneath the tank. Max. Pressure: 16 bar	

All accessories as pressure gauge, condensate drains (the manual drain as well) and other options if requested will then be supplied separately with different code.